

ClearVue

ROOFING
SYSTEM



BRANZ Appraised
Appraisal No. 877

DESIGN & INSTALLATION GUIDE

VERSION 1.1 | APRIL 2026

PSP MATERIALS
PRODUCTS
SOLUTIONS

SHEET NUMBER	SHEET TITLE
PCV-00	INDEX
PCV-01	CLEARVUE RAFTER BRACKETS
PCV-02	CLEARVUE EXTRUSIONS
PCV-03	CLEARVUE END PLATES AND END CAPS
PCV-04	MECHANICAL FIXINGS
PCV-05	MECHANICAL FIXINGS

CLEARVUE ROOFING SYSTEM TO BE INSTALLED AND FIXED TO SUITABLE STRUCTURAL SUPPORT, COMPLYING WITH RELEVANT CLAUSES OF THE NZBC AND THE NEW ZEALAND BUILDING ACT.

NOTE: RECOMMENDED ROOF PITCH 5°. MINIMUM ROOF PITCH OF 3°, CONSULT YOUR PSP AGENT FOR SUITABLE APPLICATIONS.

NOTE: As a supplier of building products, PSP provides technical information and product details that a suitably qualified person may rely on when certifying the portion of their design that relates to PSP products and installation requirements. However, PSP does not undertake building design work . As a result, PSP is unable to provide a PS1.

SHEET NUMBER	SHEET TITLE
PCV-RTF-BV-02	APRON DETAIL - SADDLE BRACKET
PCV-RTF-MB-02	APRON DETAIL - SADDLE BRACKET
PCV-RTF-FC-D2	APRON DETAIL - SADDLE BRACKET
PCV-RTF-FC-C2	APRON DETAIL - SADDLE BRACKET
PCV-RTF-WB-D2	APRON DETAIL - SADDLE BRACKET
PCV-RTF-WB-C2	APRON DETAIL - SADDLE BRACKET
PCV-RTF-RF-SB6	APRON DETAIL - SADDLE BRACKET
PCV-RTF-LS-A1	LONGSPAN DETAIL - PURLINS
PCV-RTF-LS-A2	LONGSPAN DETAIL - SPANBARS

RETROFIT DETAILS	
PCV-RTF-BV-02	APRON DETAIL - SADDLE BRACKET
PCV-RTF-MB-02	APRON DETAIL - SADDLE BRACKET
PCV-RTF-FC-D2	APRON DETAIL - SADDLE BRACKET
PCV-RTF-FC-C2	APRON DETAIL - SADDLE BRACKET
PCV-RTF-WB-D2	APRON DETAIL - SADDLE BRACKET

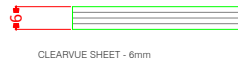
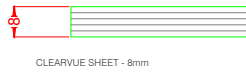
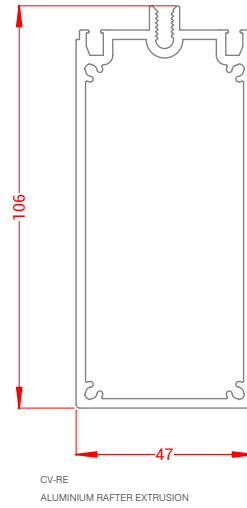
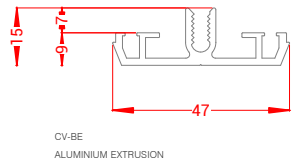
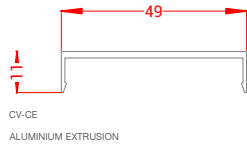
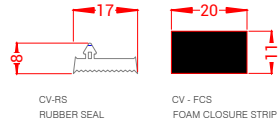
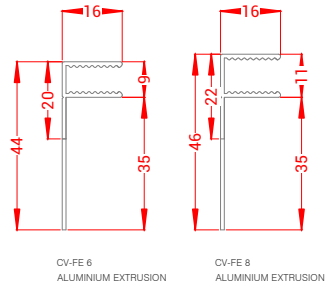

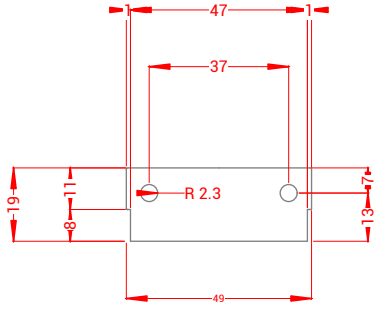

CV-EP6-01
END PLATE

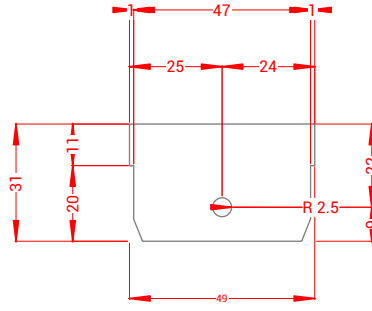

CV-EP6-02
END PLATE

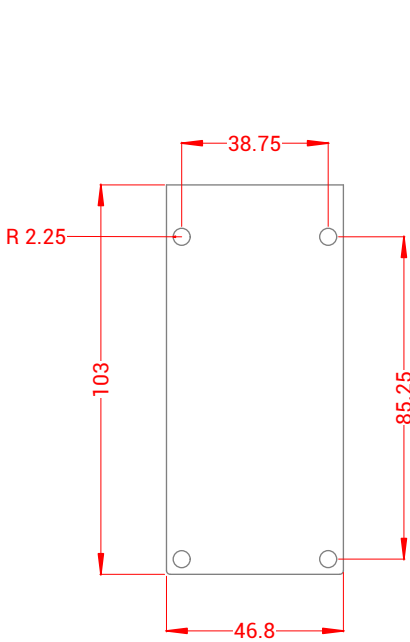

CV-EP-03
END PLATE

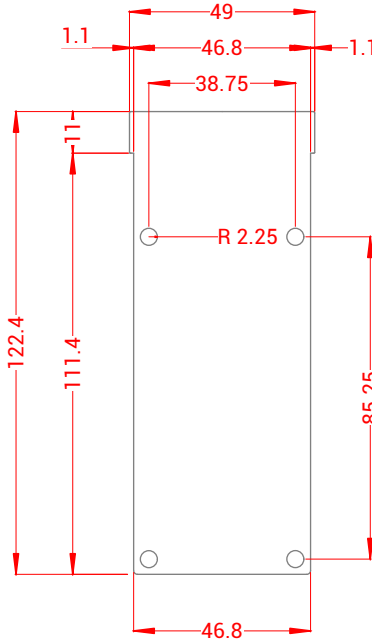

CV-EP6-04
END PLATE

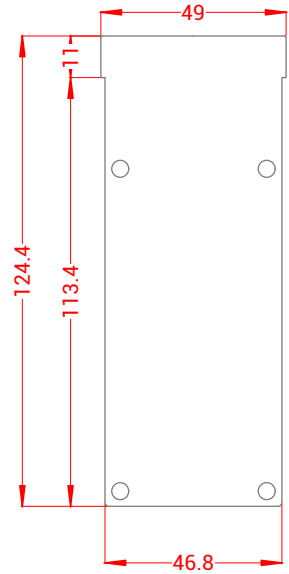

CV-EP8-04
END PLATE

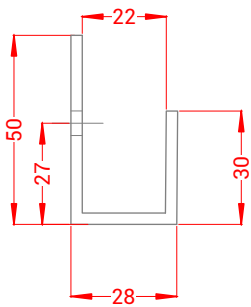

CLV-SPAN CAPU8

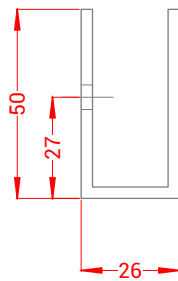

CLV-SPAN CAPU6

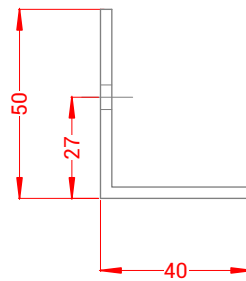

CLV-UNI-END CAP

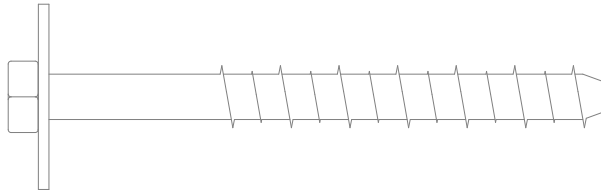
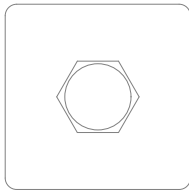

CV-F09

M12 x 150mm GALVANISED FORTRESS
SCREW BOLT WITH GALVANISED M12
SQUARE WASHER

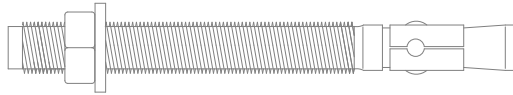

CV-F10

M12 x 135mm STAINLESS STEEL 316
THROUGH BOLT WITH STAINLESS STEEL
316 ROUND WASHER

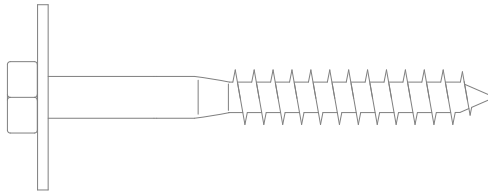
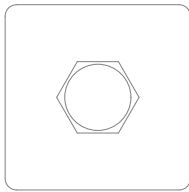

CV-F11

FIXING - PSP M12 STAINLESS STEEL 316
COACH SCREW WITH STAINLESS STEEL
316 M12 SQUARE WASHER



CV-F01

6g SQUARE DRIVE STAINLESS STEEL 316
FIXING SCREW



CV-F02

10g SQUARE DRIVE STAINLESS STEEL 316
FIXING SCREW



CV-F03

8g x 50mm SQUARE DRIVE SELF TAPPERS
STAINLESS STEEL 316 FIXING SCREW



CV-F04

HEX DRIVE, UNC THREAD STAINLESS
STEEL 316 SOCKET CAP SCREW



CV-F05

12g x 25mm HEX FLANGE STAINLESS
STEEL 316 SELF DRILLING SCREW



CV-F06

12g x 35mm HEX FLANGE TYPE 17
STAINLESS STEEL 316 FIXING SCREW



CV-F07

M6 x 12mm HEX DRIVE STAINLESS STEEL
316 SOCKET SCREW



CV-F08

10g x 32mm COUNTER SUNK SQUARE
DRIVE STAINLESS STEEL 316 FIXING
WOOD SCREW

FLASHING WIDTH TABLE - 'X'mm (BASED ON TABLE 7, E2/AS1, 24 DECEMBER 2011)			
SITUATION 1:	LOW, MEDIUM OR HIGH WIND ZONES, WHERE ROOF PITCH IS GREATER THAN OR EQUAL TO 5°.		
SITUATION 2:	ALL ROOF PITCHES IN VERY HIGH WIND ZONES. VERY HIGH WIND ZONE WHERE ROOF PITCH IS LESSER THAN OR EQUAL TO 5°.		
SITUATION 3:	ALL ROOF PITCHES IN EXTRA HIGH WIND ZONES.		
	SITUATION 1 (MINIMUM)	SITUATION 2 (MINIMUM)	SITUATION 3 (MINIMUM)
TRANSVERSE FLASHING	130	200	200

PSP - ALUMINIUM & TIMBER RAFTER SPACING TABLE		
SHEET THICKNESS	6mm SHEET	8mm SHEET
ALUMINIUM RAFTER SPACING	600 crs	750 crs

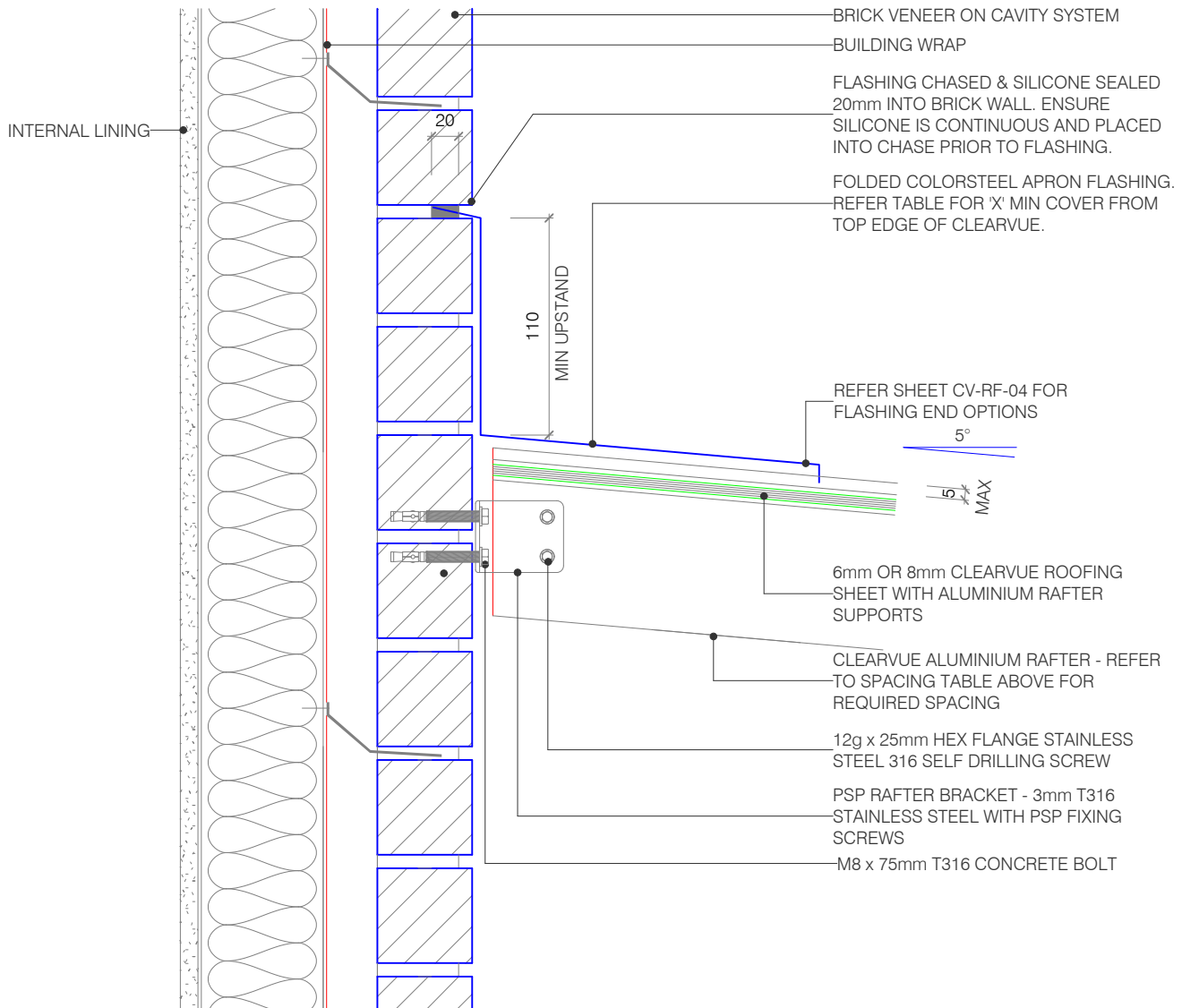

NOTE: Recommended roof pitch 5°. Minimum roof pitch of 3°, consult your PSP agent for suitable applications.

NOTE: All dimensions are in millimeters (mm)

FLASHING WIDTH TABLE - 'X'mm (BASED ON TABLE 7, E2/AS1, 24 DECEMBER 2011)

- SITUATION 1:** LOW, MEDIUM OR HIGH WIND ZONES, WHERE ROOF PITCH IS GREATER THAN OR EQUAL TO 5°.
- SITUATION 2:** ALL ROOF PITCHES IN VERY HIGH WIND ZONES. VERY HIGH WIND ZONE WHERE ROOF PITCH IS LESSER THAN OR EQUAL TO 5°.
- SITUATION 3:** ALL ROOF PITCHES IN EXTRA HIGH WIND ZONES.

	SITUATION 1 (MINIMUM)	SITUATION 2 (MINIMUM)	SITUATION 3 (MINIMUM)
TRANSVERSE FLASHING	130	200	200

PSP - ALUMINIUM & TIMBER RAFTER SPACING TABLE

SHEET THICKNESS	6mm SHEET	8mm SHEET
ALUMINIUM RAFTER SPACING	600 crs	750 crs

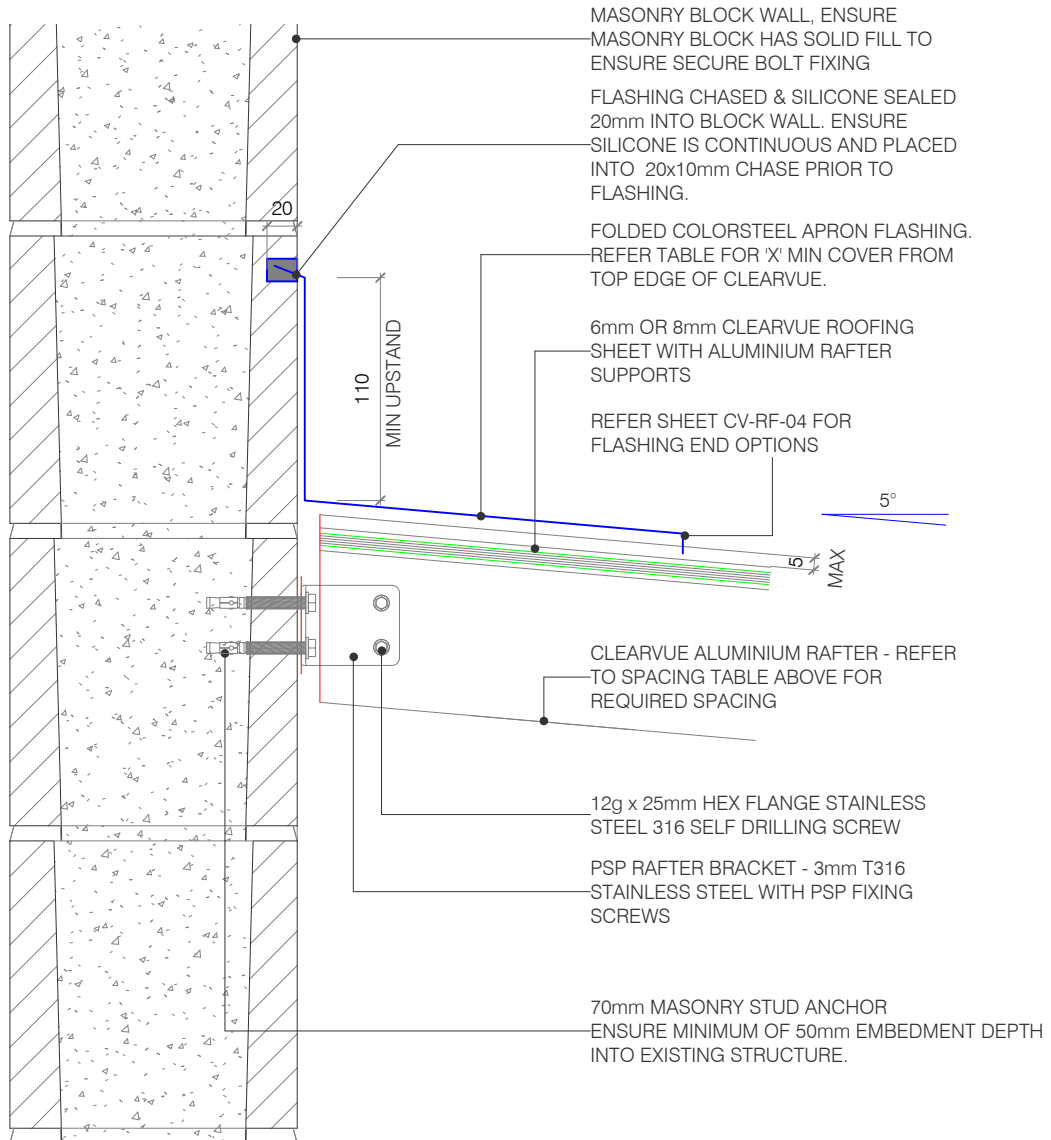

NOTE: Recommended roof pitch 5°. Minimum roof pitch of 3°, consult your PSP agent for suitable applications.

NOTE: All dimensions are in millimeters (mm)

FLASHING WIDTH TABLE - 'X'mm
(BASED ON TABLE 7, E2/AS1, 24 DECEMBER 2011)

SITUATION 1:	LOW, MEDIUM OR HIGH WIND ZONES, WHERE ROOF PITCH IS GREATER THAN OR EQUAL TO 5°.		
SITUATION 2:	ALL ROOF PITCHES IN VERY HIGH WIND ZONES. VERY HIGH WIND ZONE WHERE ROOF PITCH IS LESSER THAN OR EQUAL TO 5°.		
SITUATION 3:	ALL ROOF PITCHES IN EXTRA HIGH WIND ZONES.		
	SITUATION 1 (MINIMUM)	SITUATION 2 (MINIMUM)	SITUATION 3 (MINIMUM)
TRANSVERSE FLASHING	130	200	200

PSP - ALUMINIUM & TIMBER RAFTER SPACING TABLE

SHEET THICKNESS	6mm SHEET	8mm SHEET
ALUMINIUM RAFTER SPACING	600 crs	750 crs

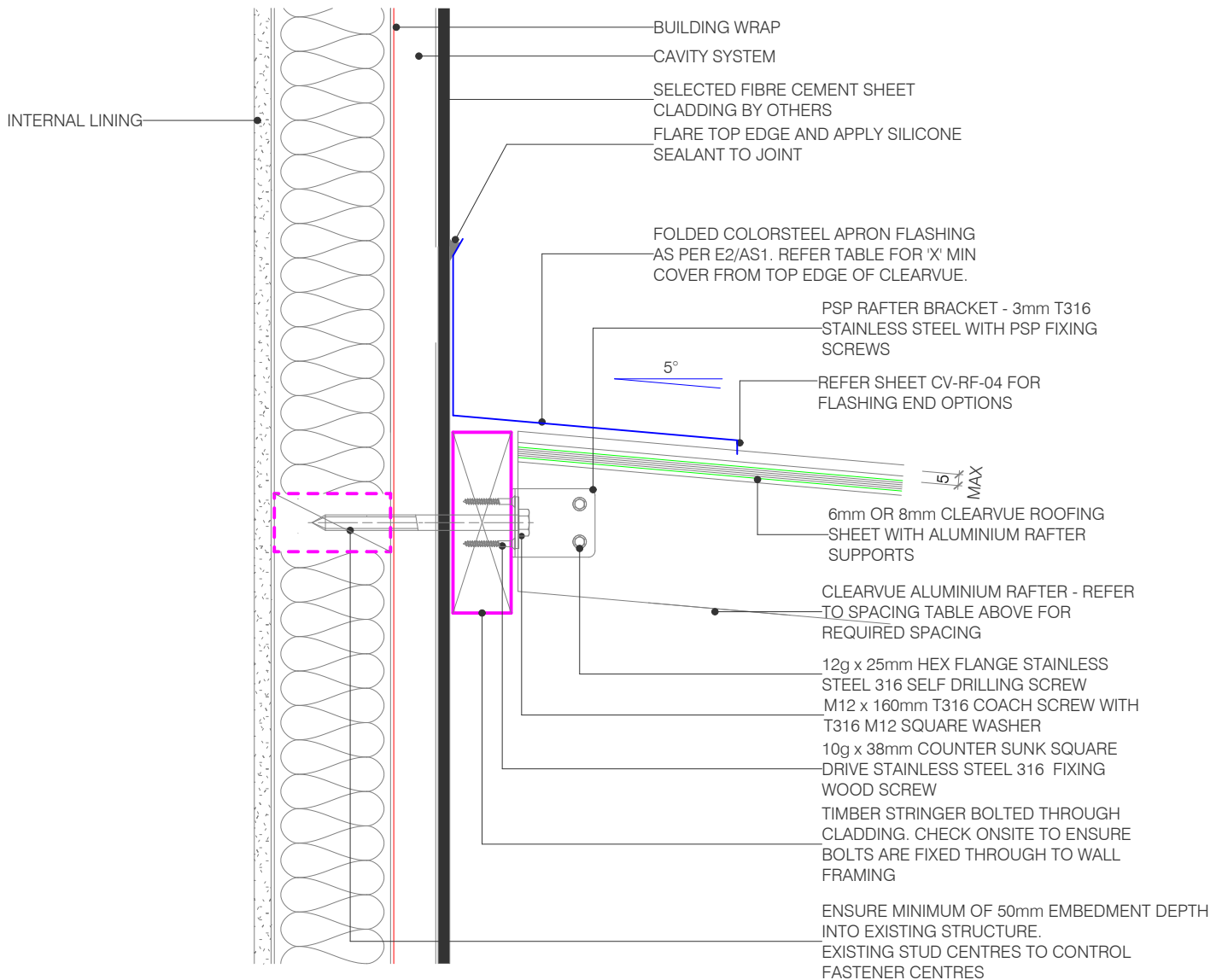

NOTE: Recommended roof pitch 5°. Minimum roof pitch of 3°, consult your PSP agent for suitable applications.

NOTE: All dimensions are in millimeters (mm)

FLASHING WIDTH TABLE - "X"mm
(BASED ON TABLE 7, E2/AS1, 24 DECEMBER 2011)

SITUATION 1:	LOW, MEDIUM OR HIGH WIND ZONES, WHERE ROOF PITCH IS GREATER THAN OR EQUAL TO 5°.		
SITUATION 2:	ALL ROOF PITCHES IN VERY HIGH WIND ZONES. VERY HIGH WIND ZONE WHERE ROOF PITCH IS LESSER THAN OR EQUAL TO 5°.		
SITUATION 3:	ALL ROOF PITCHES IN EXTRA HIGH WIND ZONES.		
	SITUATION 1 (MINIMUM)	SITUATION 2 (MINIMUM)	SITUATION 3 (MINIMUM)
TRANSVERSE FLASHING	130	200	200

PSP - ALUMINIUM & TIMBER RAFTER SPACING TABLE

SHEET THICKNESS	6mm SHEET	8mm SHEET
ALUMINIUM RAFTER SPACING	600 crs	750 crs

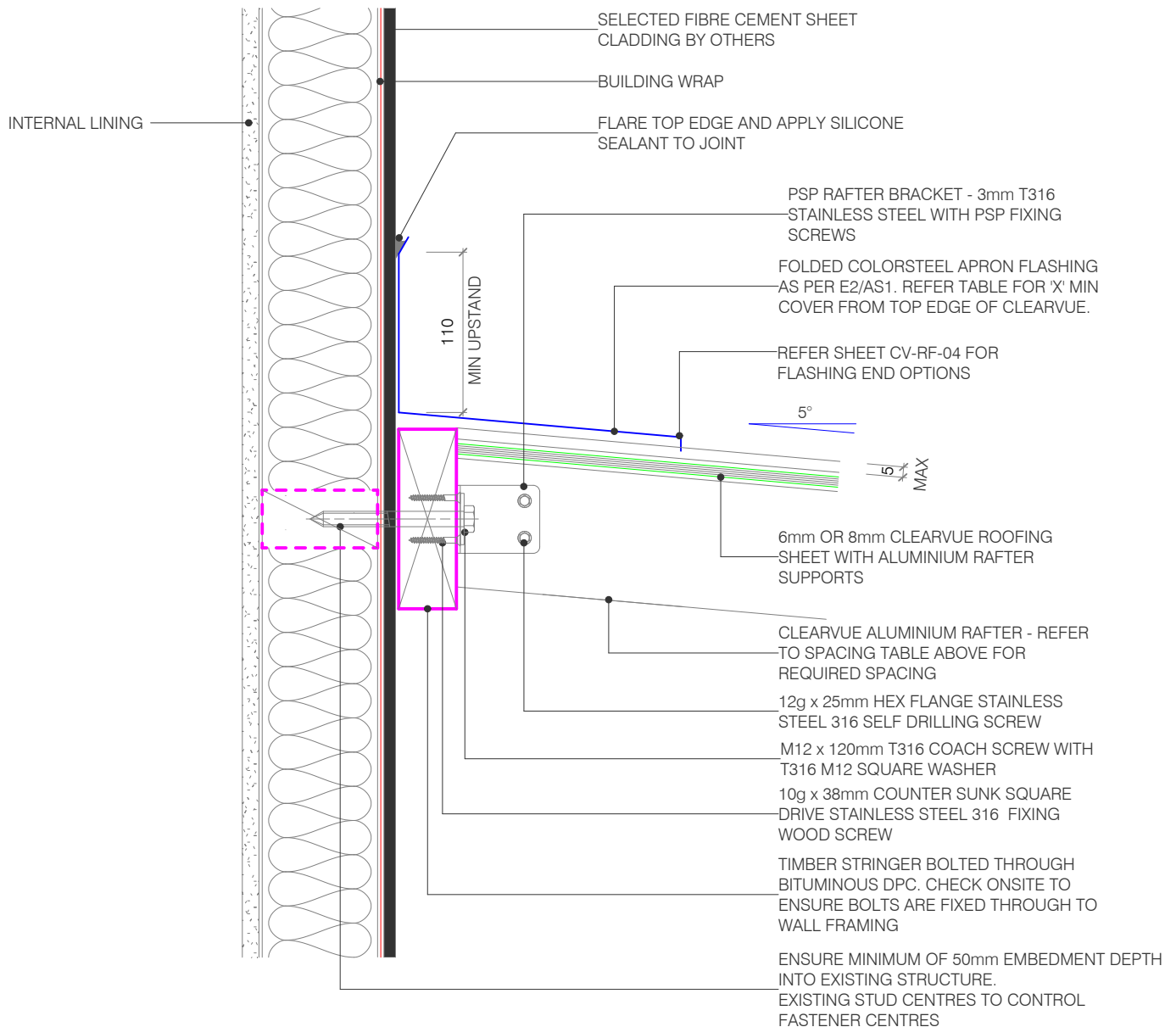

NOTE: Recommended roof pitch 5°. Minimum roof pitch of 3°, consult your PSP agent for suitable applications.

NOTE: All dimensions are in millimeters (mm)

FLASHING WIDTH TABLE - "X"mm (BASED ON TABLE 7, E2/AS1, 24 DECEMBER 2011)

- SITUATION 1:** LOW, MEDIUM OR HIGH WIND ZONES, WHERE ROOF PITCH IS GREATER THAN OR EQUAL TO 5°.
- SITUATION 2:** ALL ROOF PITCHES IN VERY HIGH WIND ZONES. VERY HIGH WIND ZONE WHERE ROOF PITCH IS LESSER THAN OR EQUAL TO 5°.
- SITUATION 3:** ALL ROOF PITCHES IN EXTRA HIGH WIND ZONES.

	SITUATION 1 (MINIMUM)	SITUATION 2 (MINIMUM)	SITUATION 3 (MINIMUM)
TRANSVERSE FLASHING	130	200	200

PSP - ALUMINIUM & TIMBER RAFTER SPACING TABLE

SHEET THICKNESS	6mm SHEET	8mm SHEET
ALUMINIUM RAFTER SPACING	600 crs	750 crs

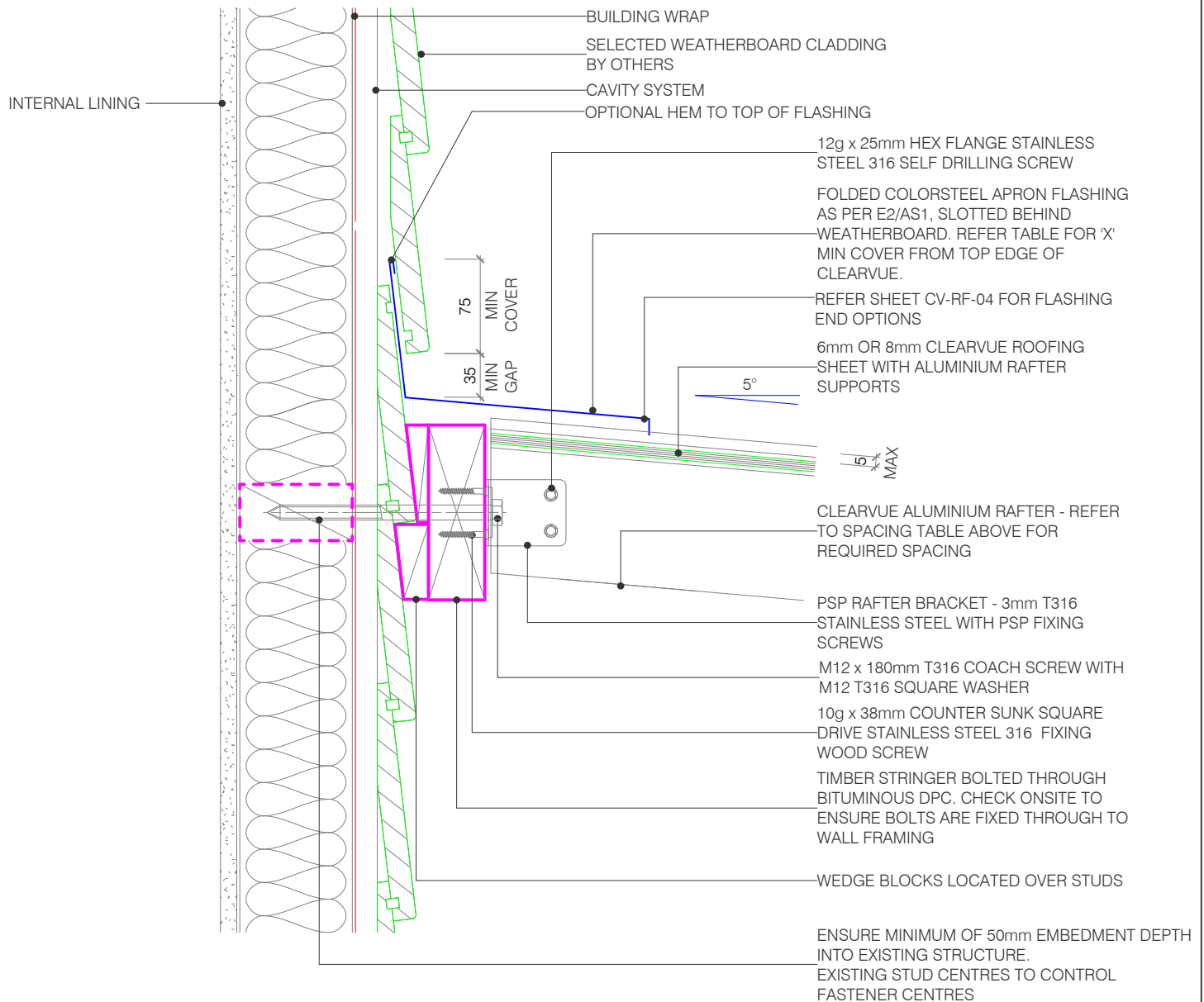

NOTE: Recommended roof pitch 5°. Minimum roof pitch of 3°, consult your PSP agent for suitable applications.

NOTE: All dimensions are in millimeters (mm)

FLASHING WIDTH TABLE - "X"mm (BASED ON TABLE 7, E2/AS1, 24 DECEMBER 2011)

- SITUATION 1: LOW, MEDIUM OR HIGH WIND ZONES, WHERE ROOF PITCH IS GREATER THAN OR EQUAL TO 5°.
- SITUATION 2: ALL ROOF PITCHES IN VERY HIGH WIND ZONES, VERY HIGH WIND ZONE WHERE ROOF PITCH IS LESSER THAN OR EQUAL TO 5°.
- SITUATION 3: ALL ROOF PITCHES IN EXTRA HIGH WIND ZONES.

	SITUATION 1 (MINIMUM)	SITUATION 2 (MINIMUM)	SITUATION 3 (MINIMUM)
TRANSVERSE FLASHING	130	200	200

PSP - ALUMINIUM & TIMBER RAFTER SPACING TABLE

SHEET THICKNESS	6mm SHEET	8mm SHEET
ALUMINIUM RAFTER SPACING	600 crs	750 crs

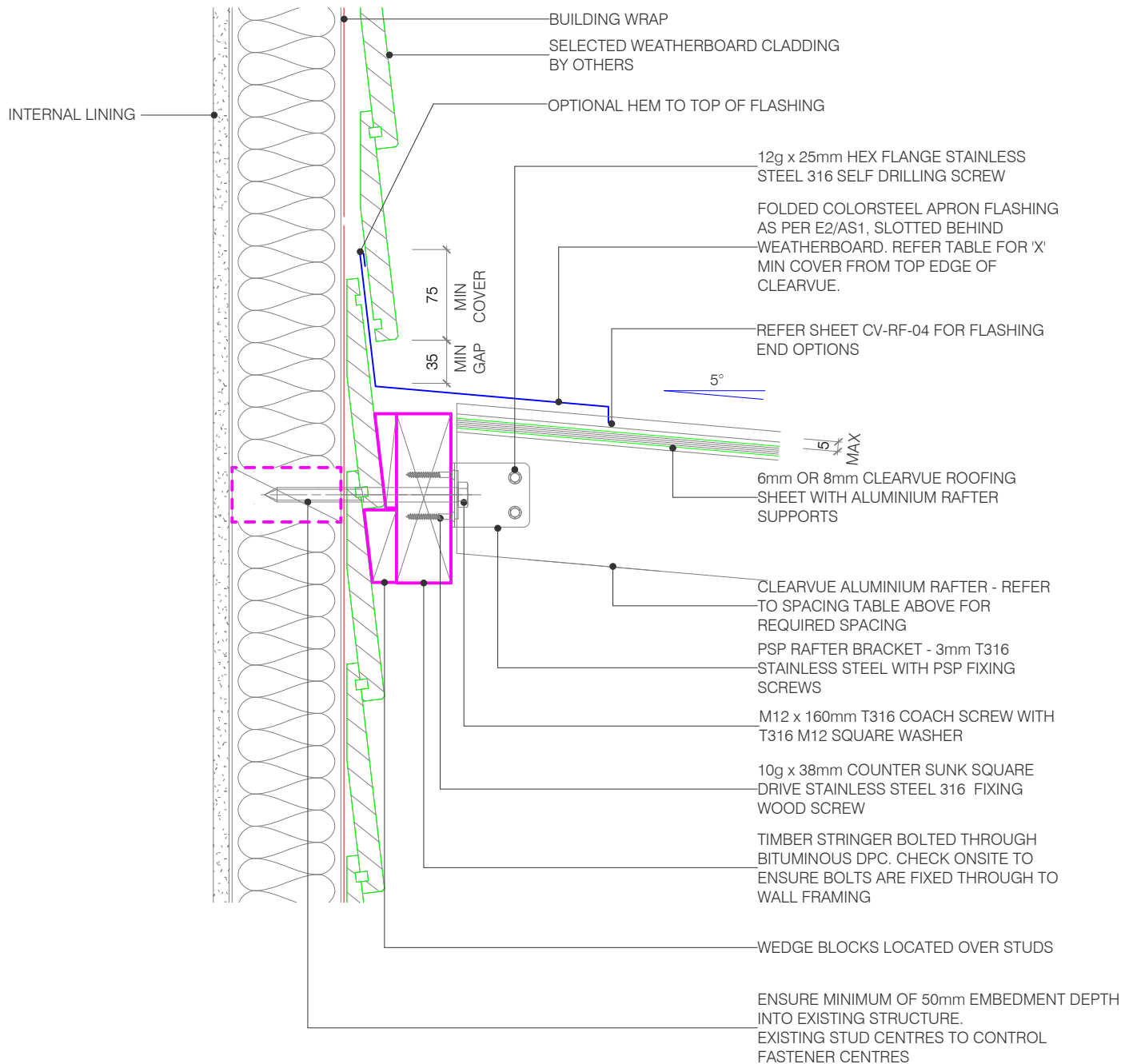

NOTE: Recommended roof pitch 5°. Minimum roof pitch of 3°, consult your PSP agent for suitable applications.

NOTE: All dimensions are in millimeters (mm)

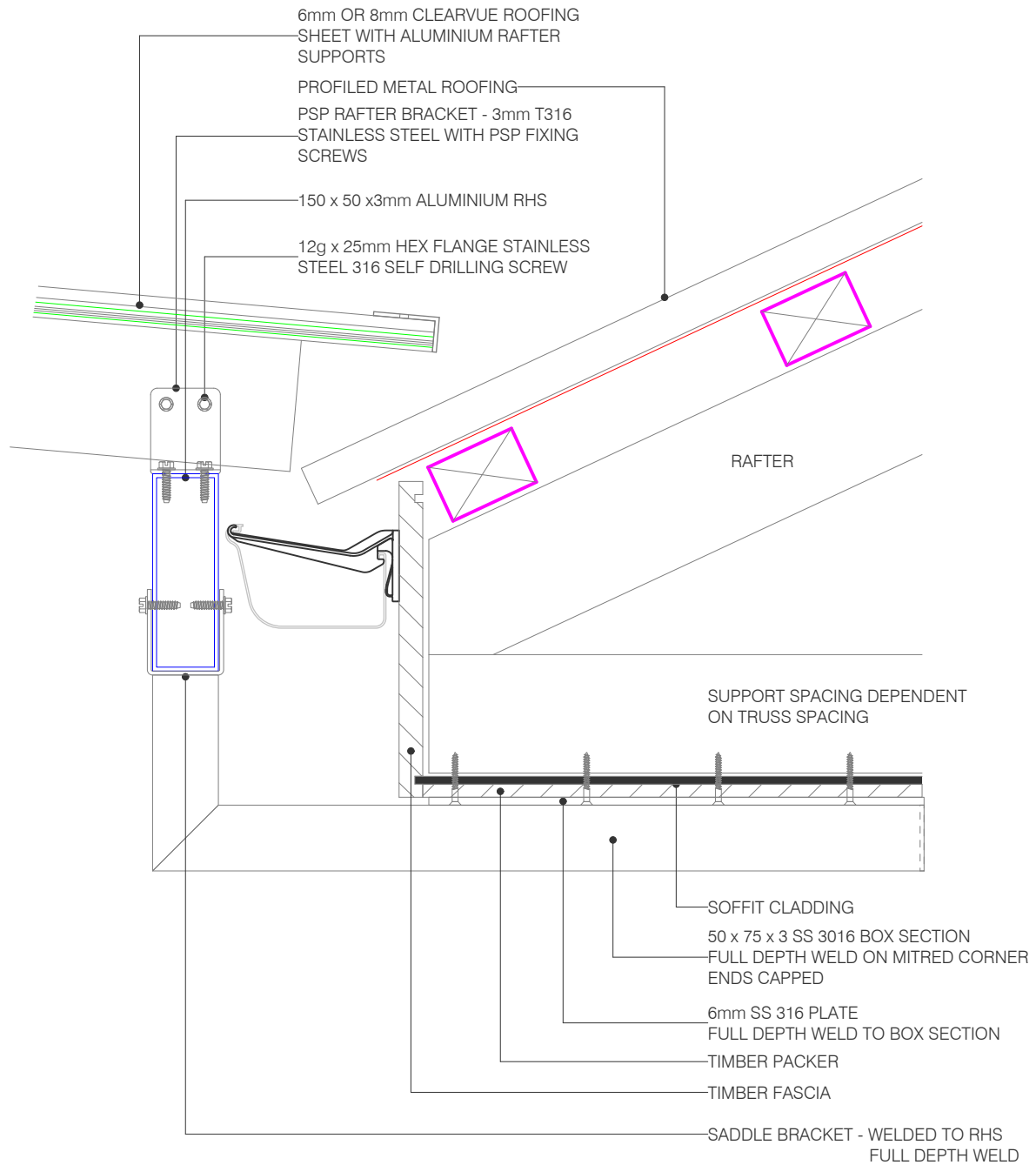

NOTE: Recommended roof pitch 5°. Minimum roof pitch of 3°, consult your PSP agent for suitable applications.

NOTE: All dimensions are in millimeters (mm)

FLASHING WIDTH TABLE - "X"mm
(BASED ON TABLE 7, E2/AS1, 24 DECEMBER 2011)

SITUATION 1:	LOW, MEDIUM OR HIGH WIND ZONES, WHERE ROOF PITCH IS GREATER THAN OR EQUAL TO 5°.		
SITUATION 2:	ALL ROOF PITCHES IN VERY HIGH WIND ZONES. VERY HIGH WIND ZONE WHERE ROOF PITCH IS LESSER THAN OR EQUAL TO 5°.		
SITUATION 3:	ALL ROOF PITCHES IN EXTRA HIGH WIND ZONES.		
	SITUATION 1 (MINIMUM)	SITUATION 2 (MINIMUM)	SITUATION 3 (MINIMUM)
TRANSVERSE FLASHING	130	200	200

PSP - ALUMINIUM & TIMBER RAFTER SPACING TABLE

SHEET THICKNESS	6mm SHEET	8mm SHEET
ALUMINIUM RAFTER SPACING	600 crs	750 crs

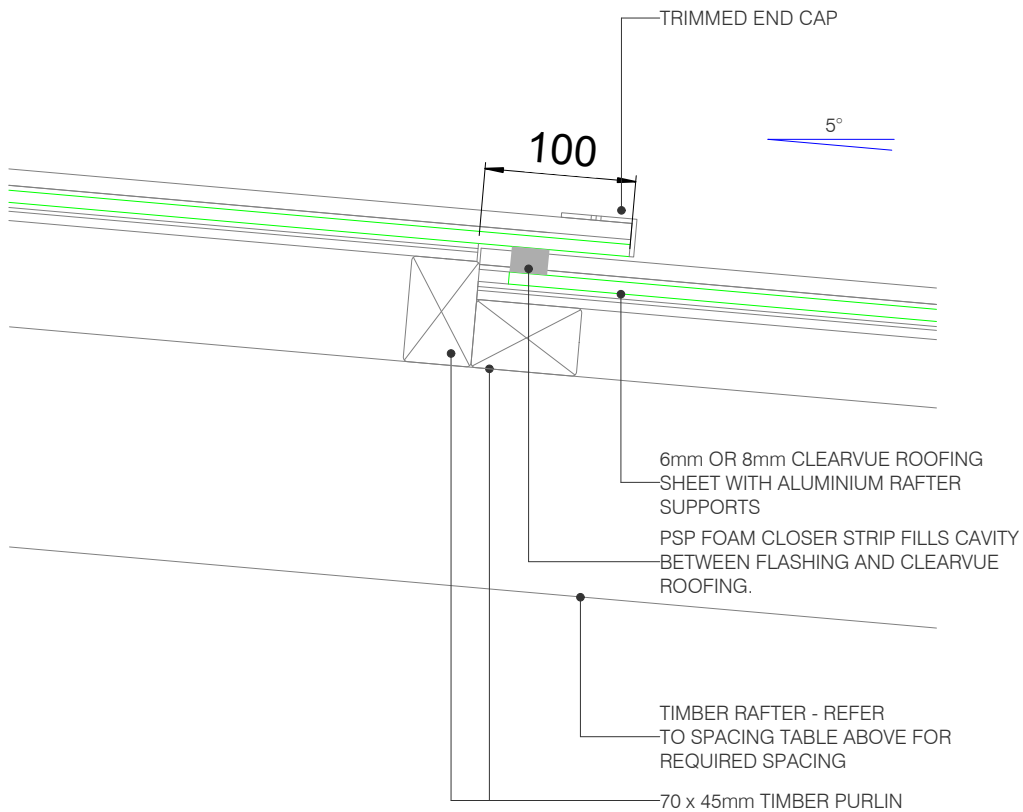

NOTE: Recommended roof pitch 5°. Minimum roof pitch of 3°, consult your PSP agent for suitable applications.

NOTE: All dimensions are in millimeters (mm)

FLASHING WIDTH TABLE - "X"mm
(BASED ON TABLE 7, E2/AS1, 24 DECEMBER 2011)

SITUATION 1:	LOW, MEDIUM OR HIGH WIND ZONES, WHERE ROOF PITCH IS GREATER THAN OR EQUAL TO 5°.		
SITUATION 2:	ALL ROOF PITCHES IN VERY HIGH WIND ZONES. VERY HIGH WIND ZONE WHERE ROOF PITCH IS LESSER THAN OR EQUAL TO 5°.		
SITUATION 3:	ALL ROOF PITCHES IN EXTRA HIGH WIND ZONES.		
	SITUATION 1 (MINIMUM)	SITUATION 2 (MINIMUM)	SITUATION 3 (MINIMUM)
TRANSVERSE FLASHING	130	200	200

PSP - ALUMINIUM & TIMBER RAFTER SPACING TABLE

SHEET THICKNESS	6mm SHEET	8mm SHEET
ALUMINIUM RAFTER SPACING	600 crs	750 crs

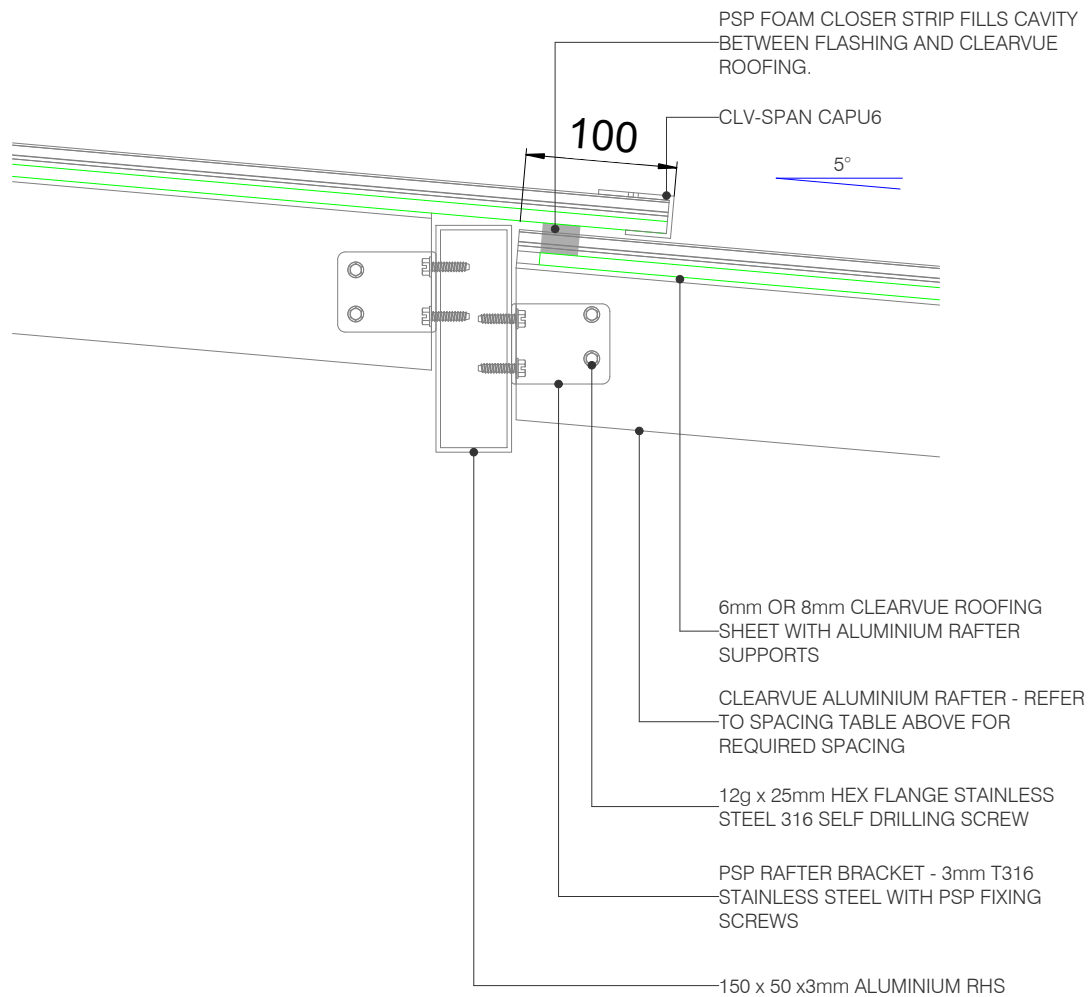

NOTE: Recommended roof pitch 5°. Minimum roof pitch of 3°, consult your PSP agent for suitable applications.

NOTE: All dimensions are in millimeters (mm)